

TRES

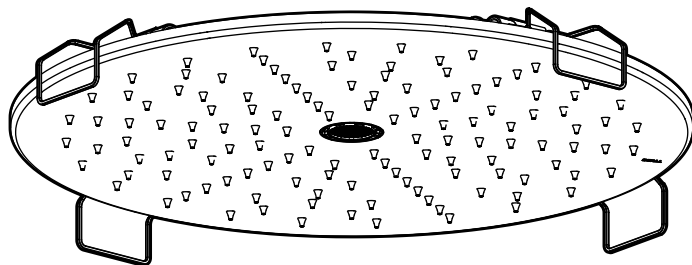

Ref. 193695102 • ed. 12AJ

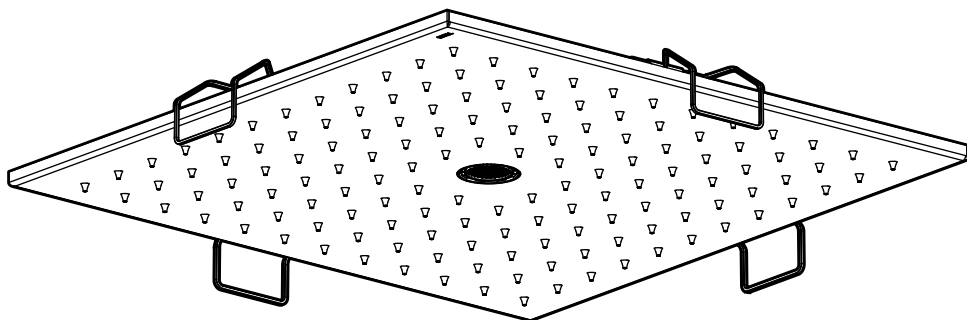

EL INCUMPLIMIENTO DE ESTAS INSTRUCCIONES EXIME DE TODA RESPONSABILIDAD A TRES GRIFERÍA • L'INCOMPLIMENT D'AQUESTES INSTRUCCIONS EXIMEIX DE TOTA RESPONSABILITAT A TRES GRIFERÍA • LE NON-RESPECT DE CES INSTRUCTIONS DÉGAGE TRES GRIFERÍA DE TOUTE RESPONSABILITÉ • DIE MISSACHTUNG DIESER ANWEISUNGEN BEFREIT TRES GRIFERÍA VON JEDLICHER HAFTUNG • NIET-NALEVVING VAN DEZE INSTRUCTIES ONTSLAAT TRES GRIFERÍA VAN ALLE VERANTWOORDELIJKHEID • L'INADEMPIMENTO DELLE PRESENTI INDICAZIONI ESONERA TRES GRIFERÍA DA QUALSIASI RESPONSABILITÀ • TRES GRIFERÍA NENESE ODPOVĚDNOST ZA ŠKODY ZPŮSOBENÉ NEDODRŽENÍM UVEDENÝCH POKYŇŮ • THE NON-FULFILMENT OF THESE INSTRUCTIONS SHALL EXEMPT TRES FROM ALL AND ANY LIABILITY • NIEPRZESTRZEGANIE NINIEJSZYCH INSTRUKCJI ZWALNIA FIRMĘ TRES GRIFERÍA Z WSZELKIEJ ODPOWIEDZIALNOŚCI • O INCUMPRIMENTO DESTAS INSTRUÇÕES ISENTA A TRES GRIFERÍA DE QUALQUER RESPONSABILIDADE • НЕСОБЛЮДЕНИЕ ДАННЫХ ИНСТРУКЦИЙ ВЛЕЧЕТ ЗА СОБОЙ ОСВОБОЖДЕНИЕ КОМПАНИИ TRES GRIFERÍA ОТ ЛЮБОЙ ОТВЕТСТВЕННОСТИ

VALORES DE CONEXIÓN • VALORS DE CONNEXIÓ • VALEURS DE BRANCHEMENT • ANSCHLUSSWERTE •
 WAARDEN VAN DE VERBINDING • VALORI DI CONNESSIONE • NASTAVENÍ PŘIPOJENÍ • FITTING CONNECTION
 SPECIFICATIONS • CHARAKTERYSTYKI PODŁĄCZENIA • CONDIÇÕES DE CONEXÃO • ПРОМЫВКА СИСТЕМЫ

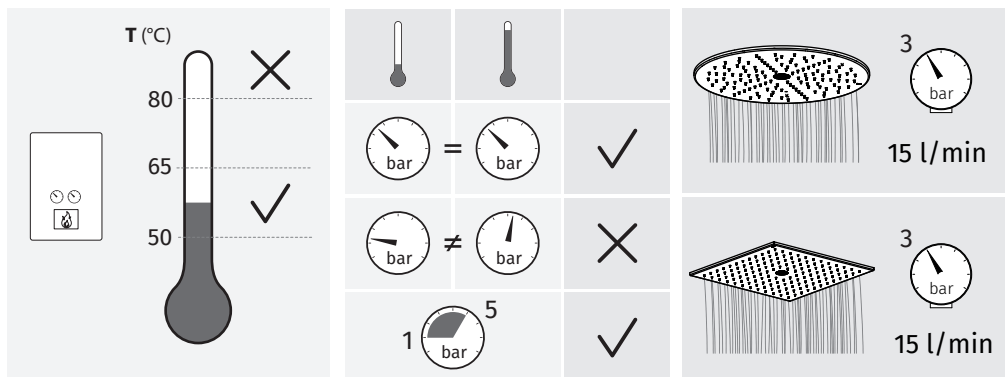

INSTALACIÓN • INSTAL·LACIÓ • INSTALLATION • INSTALLATION • INSTALLATIE • INSTALLAZIONE • INSTALACE •
 INSTALLATION • MONTÁŽ • INSTALAÇÃO • УСТАНОВКА

1

405 x 405

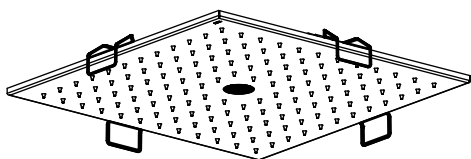

Ø405

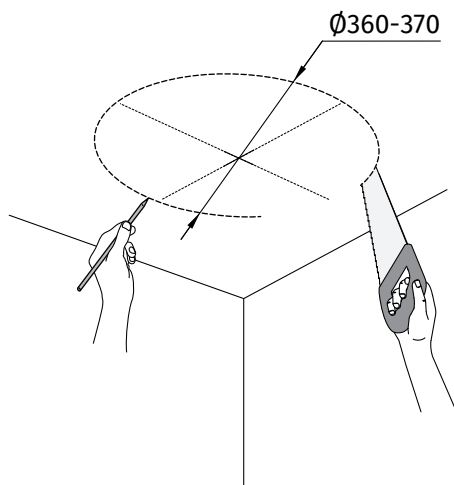
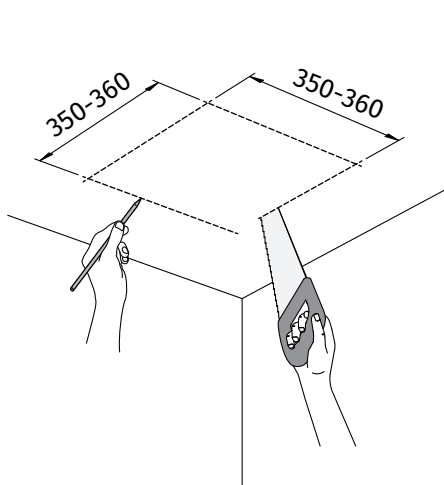
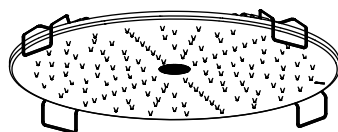

2

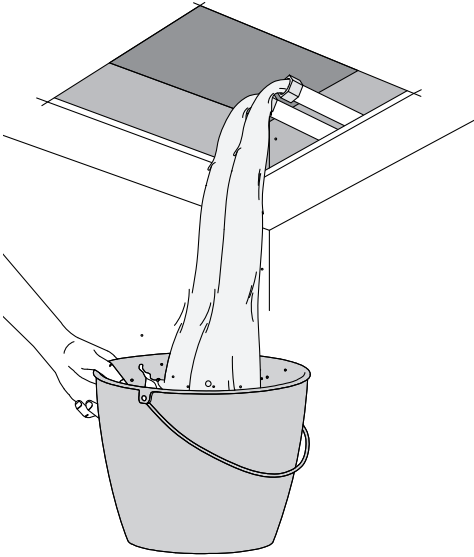

- es** En instalaci3n en placas simples de pladur, recomendamos realizar un refuerzo perimetral.
- ca** En instalaci3n en plaques simples de pladur, recomanem realitzar un reforç perimetral.
- fr** Pour toute installation sur des plaques simples en pladur, nous recommandons de poser un renfort p3rim3trique.
- de** F3r die Montage auf einfachen Gipskartonplatten empfehlen wir eine Randverst3rkung anzubringen.
- it** Sulle pareti in cartongesso consigliamo di aggiungere un rinforzo perimetrale.
- en** For installation on simple plasterboard panels, we recommend a surrounding reinforcement.
- pl** W przypadku monta¿u na prostych p³ytach gipsowo-kartonowych zalecamy wzmocnienie obwodowe.
- pt** Na instala33o em placas simples de pladur, recomendamos realizar um reforço perimetral.

3

G1/2"

21

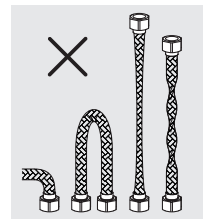
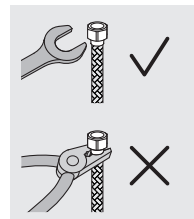
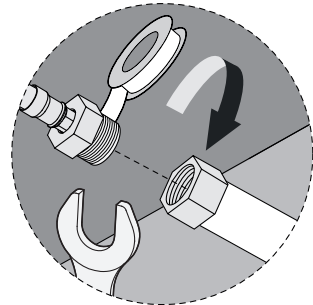
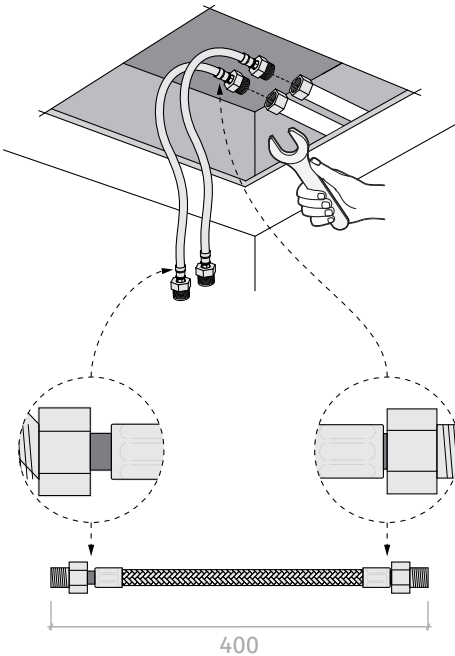

4

G1/2"

21

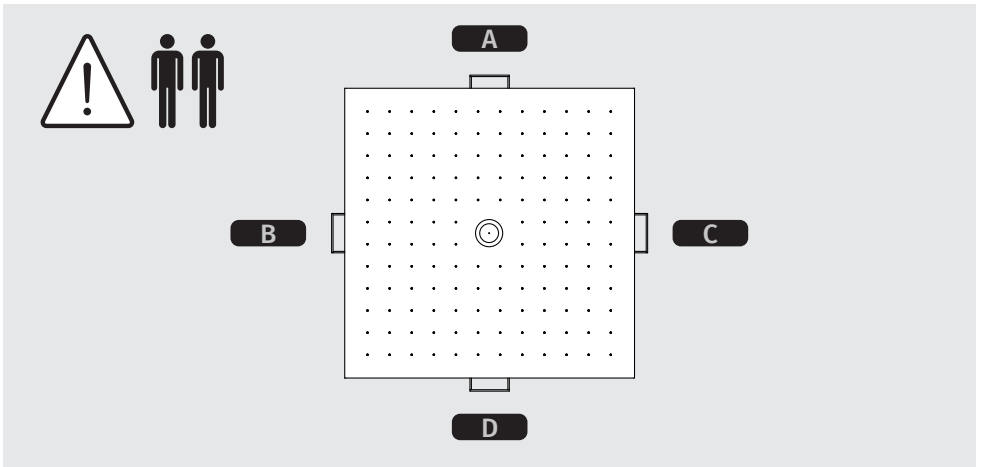
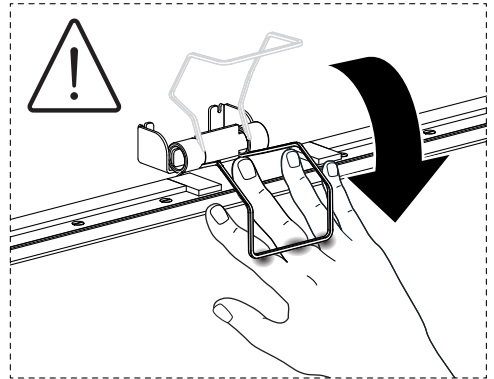
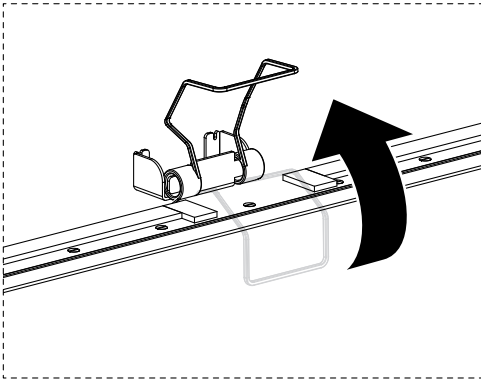
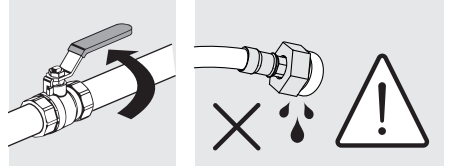
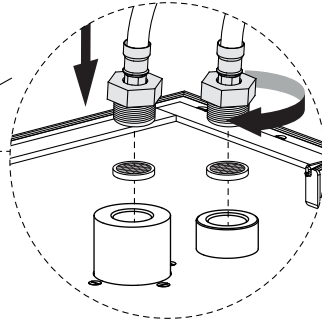
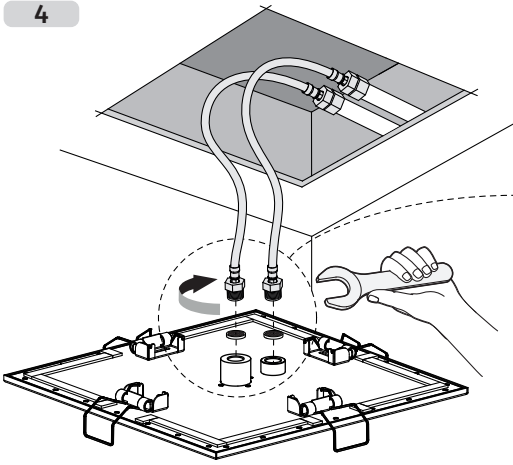

5

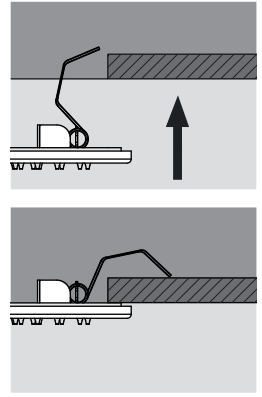
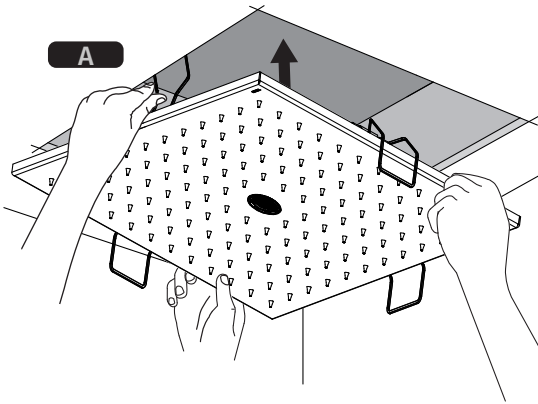

6

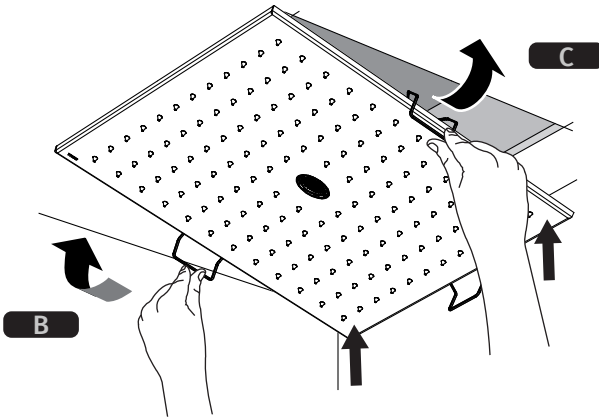

7

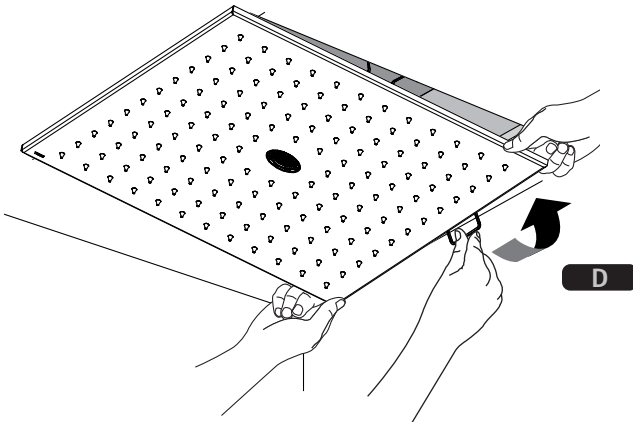

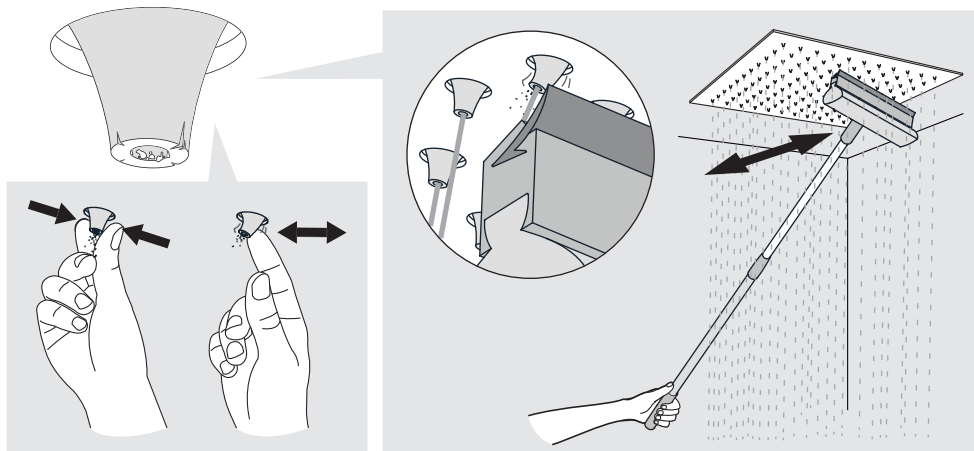

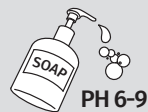



TRES COMERCIAL, SA | C/ Penedès, 16-26 · Zona Industrial, Sector A · 08759 Vallirana
comercialtres@tresgriferia.com · (+34) 93 683 40 27 · www.tresgriferia.com